



*Ready to Perform  
To Your Applications*



[www.mitforklift.com.sg](http://www.mitforklift.com.sg)

Copyright © 2009 by MCFS, All Rights Reserved. All registered trademarks are the property of their respective owners. Printed in Singapore.

FMIT0080-01

(04/09)

PRESENTED BY:

Note: Performance specifications may vary depending on standard manufacturing tolerances, vehicle condition, types of tyres, floor or surface conditions, applications or operating environment. Trucks may be shown with non-standard options. Specific performance requirements and locally available configurations should be discussed with your Mitsubishi forklift truck dealers. Mitsubishi Forklift Trucks follows a policy of continual product improvement. For this reason, some materials, options and specifications could change without notice.

# **FB-CA**

S E R I E S

4-Wheel Electric Pneumatic Tyre

1.0-3.0 ton



# **Mitsubishi** *Forklift Trucks* **FB-CA Series**



## **Delivering What You Need**

Four-wheel electric Mitsubishi forklift trucks match up to engine-powered forklift trucks in performance. Standard features like energy-efficient AC drive and hydraulic motors, a regenerative braking system, performance mode-setting and on-board diagnostics add to the value. The trucks can be tailored to the specific needs of the work application, environment and performance level.

These highly adaptable and efficient electric forklift trucks are the result of our company-wide commitment to build forklifts trucks that deliver Performance with Efficiency, and Safety with Comfort. Indeed, delivering what you need is our obsession.

# ADVANCED TECHNOLOGY

**AC Power** is a revolutionary technology that gives unsurpassed performances to forklift truck operations. The system not only provides a seamless interaction between the operator and machine, it also demonstrates more powerful functional capabilities in truck travelling, hydraulic manoeuvres and power steering.

## ENERGY-SAVING DESIGN

The various devices on board are designed to be efficient in energy use, through an assortment of regenerative features that conserve battery power and contribute to higher productivity.

Conceptual Drawing of the Energy Regeneration System

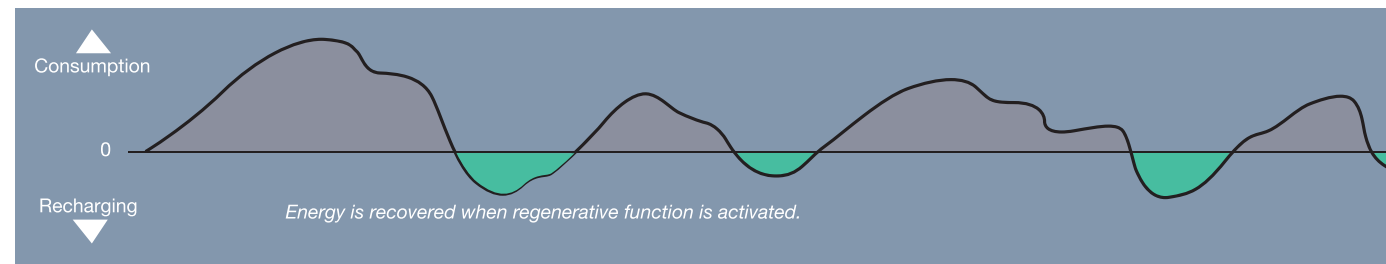

### BRAKING

Depressing the brakes transmits electrical power back to the battery. The brakes are designed to be more sensitive to foot pressure so that wearing of the brake lining is reduced, thus extending the lifespan of the lining.

### PLUGGING

When the forklift truck is travelling, reversing direction allows electrical energy to be transferred from the motor back to the battery.

### COASTING

This feature creates a sensation of gradual deceleration. It is activated when the accelerator is released while on the move. At the same time braking energy is recovered by the battery.

### SPEED CONTROL ON SLOPES

The forklift truck is able to maintain the same speed after your foot is removed from the accelerator when descending a slope. At the same time, the battery recovers energy. The FB-CA series is also equipped with a "creep" feature that helps the vehicle to start moving forward gently after stopping on a slope.

### MULTIPLE DRIVING MODES

AC Power enables the power setting to be selected between eight driving modes, from the energy-saving "ECONOMY" mode to the "POWER" mode, according to the requirements of the task. Optimal power is used for the job, thus achieving energy efficiency.

### AUTOMATIC POWER OFF

Power is automatically cut when the forklift truck is left to idle for more than 15 minutes. This is designed to conserve energy.

### LASER POINTER (OPTIONAL)

A transmitter projects a red laser beam on the pallet to indicate where the fork will reach, so that work can be carried out even under poor lighting. Levelling lamps help operators level forks when they are unable to do it with their eyes alone. This feature by Mitsubishi Forklift Trucks raises work efficiency and enhances safety.

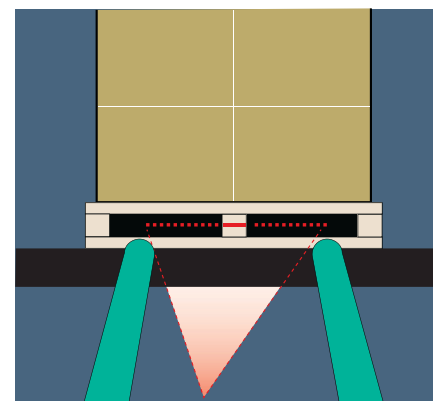

# ECONOMICAL

## LOW OPERATING COST

The cost of an electric forklift truck is higher than that of an engine-powered one. However, in the long run, it will cost less because it is more economical to operate. In addition, the FB-CA series gives the same level of working power as an engine-powered truck. This offers power with savings.

## LOW MAINTENANCE COST

AC Power allows the elimination of motor brushes and contactors, thereby reducing the cost of maintenance.





# PERFORMANCE



## TURNING RADIUS

The FB-CA series is more compact than conventional models, and has an even smaller minimum turning radius to facilitate operation in confined spaces. Speed-sensitive electric power steering (SEPS) makes steering while travelling at low speeds easier than ever.

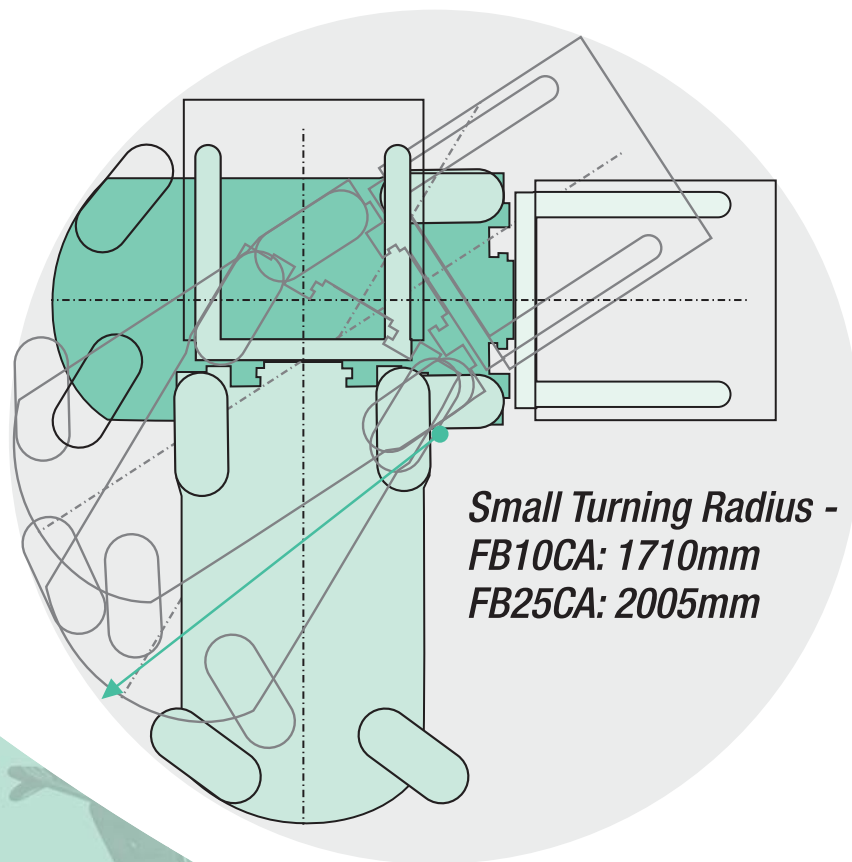

## AC POWER

The use of AC technology in the operating system allows Mitsubishi Forklift Trucks to achieve superior performance on the machines. Large traction and hydraulic motors are used to deliver greater power.

## LIFTING AND LOWERING

A high-powered motor is used to achieve one of the highest lifting speeds in the industry. In addition, the mast mechanism is designed to absorb shocks created by fast lifting (Lifting Shock Absorption\* feature) and fast lowering (Soft Landing feature).

\*Available on duplex and triplex masts only.

## NARROW AISLE WIDTH FOR RIGHT-ANGLED STACKING

Right-Angled Stacking can now be performed in a narrower aisle. Required aisle width has been reduced through a smaller turning radius, by adopting a new mast structure and by modifying frame dimensions. Together with the inching capability enabled by AC Power, the FB-CA series forklift trucks operate with greater ease in confined spaces.

## ACCELERATION AND INCHING

Both quick acceleration and smooth, gradual inching can be achieved by stepping on the same pedal. AC Power enables such delicate operations not offered by conventional forklift trucks.

## DESCENDING

The FB-CA series descends a slope with lesser dependence on its brakes and has a lower risk of slipping. Operators can now continue a descent at a constant speed when they have taken their foot off the accelerator. The "creep" feature enables operators to start moving gently after stopping on a slope.

## GRADEABILITY

Its enhanced power enables the new FB-CA series to climb slopes easier than conventional models.

THIS GRAPH COMPARES THE ACCELERATION TIME AND CONTROL CAPABILITIES OF A CONVENTIONAL DC AND FB-CA SERIES.

### CONVENTIONAL DC MODEL

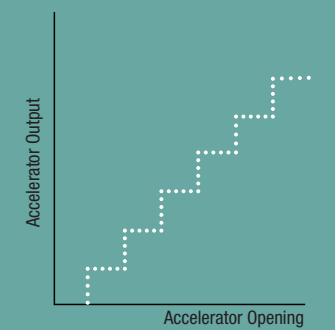

### FB-CA SERIES

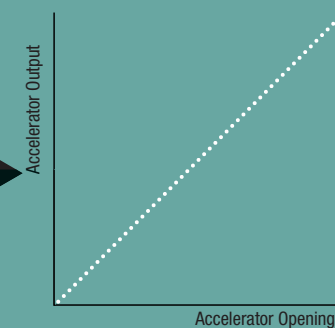

# SAFETY AND COMFORT

## EASY-TO-READ DISPLAY

The vacuum fluorescent display (VFD) is located in the centre of the operator's compartment to allow quick access to important information. Data on travelling speed, battery discharge status, current time and key-on hours are displayed in real time. Characters and symbols used are easy to read and understand, so users can monitor machine and work conditions effortlessly.



## MAST AND TRAVEL INTERLOCK

If the operator is not properly seated within two seconds, the mast and travel interlock safety feature will be activated, which means the hydraulic and transmission operations are locked. This safety feature is essential in forklifts because it prevents fatal forklift accidents that happen mostly when operators are not seated.



## NEUTRAL SAFETY SYSTEM

During key-on, if any of the hydraulic levers is accidentally actuated, or when the accelerator pedal is depressed together with the FNR lever in "F" or "R" position, an error message will appear on the display, leaving the forklift truck immobilised until the error is rectified. This safety system prevents accidents that may be caused by unexpected movement of the forklift truck at key-on.



## MAST WITH SHOCK-REDUCTION FEATURES

The Soft Landing feature is installed as standard equipment on the mast. The lowering speed of the forks is automatically reduced when they approach the ground. Forklift trucks with duplex or triplex masts are also provided with a Lifting Shock Absorption feature to reduce the "knocking" impact when the inner mast channels extend. These features help to reduce noise and potential damages to the load.

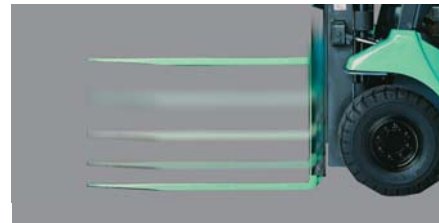

## EASIER ON-OFF ACCESS

The new FB-CA series has a lower and wider step to make getting on and off an easy task. A well-positioned grip, as well as a palm pad built onto the battery cover, help make on-off access easier, even if the driver is wearing gloves.



## COMFORTABLE OPERATOR'S COMPARTMENT

The new mast design provides the operator a wider angle of view. A tiltable steering column allows the operator to operate at the desired comfortable position. Ample leg space offers greater operator comfort and the floor mat provides secure footing even under wet conditions. A convenient cup holder is also a standard item on the dashboard.

## OPERATOR'S SEAT

The seat is ergonomically designed to fit the operator so as to maintain the optimal driving posture. This minimises fatigue even after an extended period of operation. The seatbelt and the "hip restraint bar" protect the operator in case of an accident. The seat is durable and water-resistant for greater comfort.



\*Deluxe Full Suspension  
ORS Seat (Optional)

# SERVICEABILITY

## SELF-DIAGNOSIS FEATURE

Mitsubishi forklift truck FB-CA series is equipped with the capability to diagnose the cause of faults automatically. In case of a problem, a message on the monitor alerts the operator. The information is also logged in the memory of the on-board computer for the reference of maintenance engineers.

## EASY ACCESS TO COMPONENTS

The design of the new FB-CA series provides hassle-free access to the various components. This allows service engineers quick and easy access to troubleshoot or service specific forklift truck machinery parts.

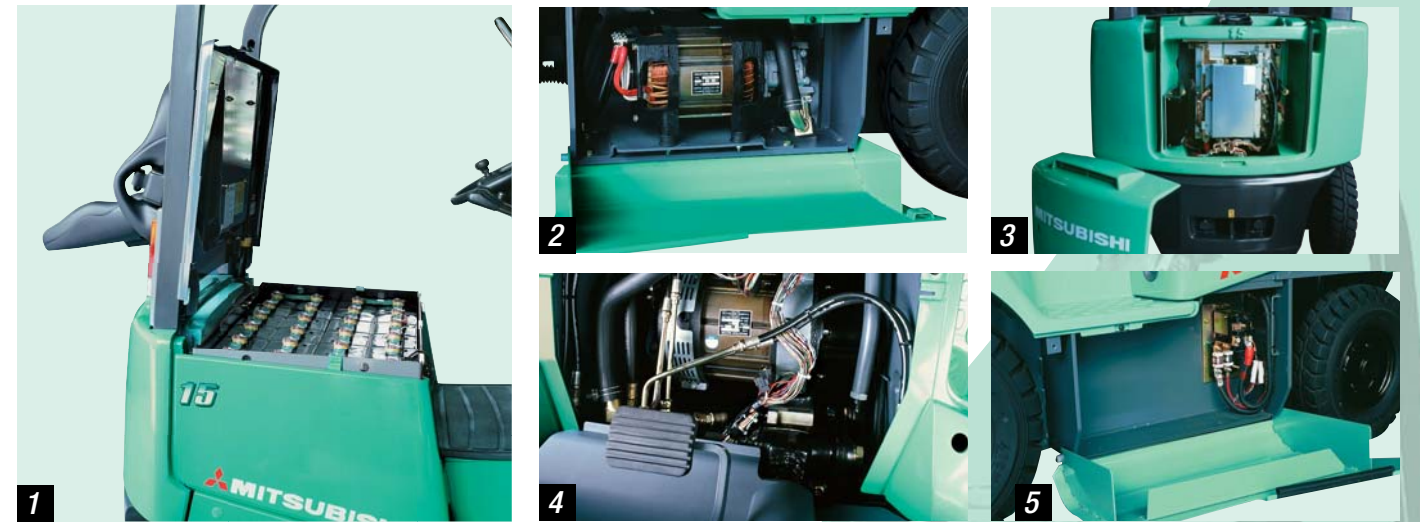

1. Battery 2. Hydraulic Motor 3. Controller 4. Traction Motor 5. Contactors





# OPTIONS



### “AOS” PRE-SET LIFTING HEIGHT MEMORY

The height of a rack can be entered into memory, so that the fork can be raised to that position with just the press of a button. When the naked eye finds it hard to position forks accurately to reach very tall racks, this system becomes very effective. This is also useful for reaching frequently-used racks.



### LARGE-CAPACITY BATTERY

The large-capacity battery lengthens the operating time for the forklift truck with each recharge, so the truck can be used over an extended period. This reduces the number of times the battery has to be recharged, and increases efficiency.



### FINGER-TIP CONTROL

Super-sensitive control levers allow effortless operation for greater productivity. As large arm movements are not necessary, operator fatigue is reduced even for extended periods of work.



### COLD STORAGE SPECIFICATIONS

This includes the semi-cold storage (CS) specification for temperatures around -35°C and full cold storage (FCS) specification for temperatures around -55°C. Cold-resistant equipment allows extended operation in low temperatures, hence increasing productivity.



### RUST RESISTANT SPECIFICATIONS

Rust-resistant parts are used for the backrest, floor and the underside of the frame, which are areas prone to rust. This is ideal for work related to marine products, whose salt content causes rusting.



### DUST RESISTANT SPECIFICATIONS

Electrical components can be modified to allow for operation in extremely dusty situations.

## FB-CA Series Electric Counterbalanced • 4-Wheel Pneumatic Tyres 48/72 Volt AC Power • 1.0 - 3.0 ton

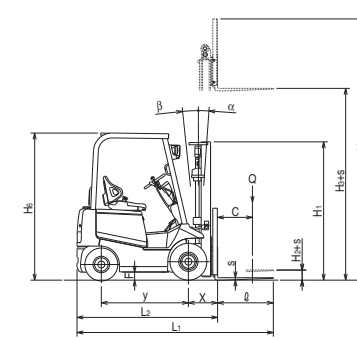
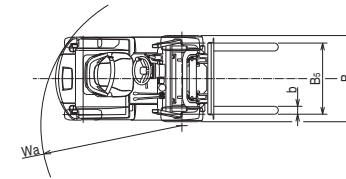

TYPE	ITEM	SUMMARY	UNIT	STANDARD SERIES								HIGH PERFORMANCE SERIES								
				FB10CA	FB14CA	FB15CA	FB18CA	FB20CA	FB25CA	FB28CA	FB30CA	FB10HCA	FB14HCA	FB15HCA	FB18HCA	FB20HCA	FB25HCA			
TYPE	1	Model		FB10CA	FB14CA	FB15CA	FB18CA	FB20CA	FB25CA	FB28CA	FB30CA	FB10HCA	FB14HCA	FB15HCA	FB18HCA	FB20HCA	FB25HCA			
	2	Rated capacity	Q	kg	1000	1350	1500	1750	2000	2500	2750	3000	1000	1350	1500	1750	2000	2500		
	3	Load center	C	mm	500	500	500	500	500	500	500	500	500	500	500	500	500	500		
	4	Operator type			Seated	Seated	Seated	Seated	Seated	Seated	Seated	Seated	Seated	Seated	Seated	Seated	Seated	Seated		
DIMENSION	5	Lift height	H <sub>3</sub> +s	mm	3000	3000	3000	3000	3000	3000	3000	3000	3000	3000	3000	3000	3000			
	6	Free lift	H <sub>2</sub> +s	mm	145	145	145	145	150	150	155	155	145	145	145	145	150	150		
	7	Tilt angle	For-/Back-ward <F:Down/Up>	α/β	deg.	<Mast> 6/12>	<Mast> 6/12>	<Mast> 6/12>	<Mast> 6/12>	<Mast> 6/12>	<Mast> 6/12>	<Mast> 6/12>	<Mast> 6/12>	<Mast> 6/12>	<Mast> 6/12>	<Mast> 6/12>	<Mast> 6/12>	<Mast> 6/12>		
	8	Carriage			Class II	Class II	Class II	Class II	Class II	Class II	Class III	Class III	Class II	Class II	Class II	Class II	Class II	Class II		
	9	Fork	Dimension (L / W / T)	l/b/s	mm	1070/100/35	1070/100/35	1070/100/35	1070/100/35	1070/122/36	1070/122/40	1070/122/44	1070/122/44	1070/100/35	1070/100/35	1070/100/35	1070/100/35	1070/122/36	1070/122/40	
	10	Spread (Max / Min)		B <sub>5</sub>	mm	900/200	900/200	900/200	900/200	1000/245	1000/245	1000/245	1000/245	900/200	900/200	900/200	900/200	1000/245	1000/245	
	11	Overall length		L <sub>1</sub>	mm	3035	3035	3035	3080	3285	3345	3410	3580	3035	3035	3035	3080	3285	3345	
	12	Length to fork face		L <sub>2</sub>	mm	1965	1965	1965	2010	2215	2275	2340	2510	1965	1965	1965	2010	2215	2275	
	13	Width	Overall width		B	mm	1050	1050	1090	1090	1175	1175	1175	1180	1050	1050	1090	1090	1175	1175
	14	Mast lowered		H <sub>1</sub>	mm	1980	1980	1980	1980	1980	1980	1980	2215	1980	1980	1980	1980	1980	1980	
	15	Mast extended		H <sub>4</sub>	mm	4000	4000	4000	4000	4000	4000	4000	4000	4000	4000	4000	4000	4000	4000	
	16	Overhead guard		H <sub>6</sub>	mm	2110	2110	2110	2110	2110	2110	2110	2225	2110	2110	2110	2110	2110	2110	
17	Overhang	Front overhang		X	mm	395	395	395	400	425	425	445	475	395	395	395	400	425	425	
18	Min. turning radius		Wa	mm	1710	1710	1710	1725	1950	2005	2060	2240	1710	1710	1710	1725	1950	2005		
19	Min. 90° turning aisle	1100 x 1100 Pallet (included 200mm for clearance)		mm	1970	1970	1970	1980	2090	2120	2150	2205	1970	1970	1970	1980	2090	2120		
20	Min. 90° stacking aisle	1100 x 1100 Pallet (included 200mm for clearance)	Ast	mm	3405	3405	3405	3425	3675	3730	3805	4015	3405	3405	3405	3425	3675	3730		
PERFORMANCE	21	Travel speed	Laden / Unladen		km/h	14.0/16.0	14.0/16.0	14.0/16.0	13.5/15.5	14.0/16.0	13.5/15.5	13.5/15.0	13.5/15.5	16.0/18.0	16.0/18.0	16.0/18.0	15.5/17.5	15.5/17.5	15.0/17.0	
	22	Lifting speed	Laden / Unladen		mm/s	370/540	340/540	320/540	310/540	280/470	260/470	250/470	320/550	470/650	440/650	420/650	380/650	360/600	340/600	
	23	Lowering speed	Laden / Unladen		mm/s	550	550	550	550	550	550	550	450	550	550	550	550	550	550	
	24	Max. drawbar pull	3min. rating, 1.5km/h and over		N															
	25	Max. gradeability	3min. rating, 1.5km/h and over		%	22.0	20.0	19.0	17.0	19.0	16.0	14.0	16.0	22.0	20.0	19.0	17.0	19.0	16.0	
MASS	26	Service weight	w/o battery (6.3)		kg	2695	2830	2950	3125	3680	4185	4400	4770	2695	2830	2950	3125	3680	4185	
	27	Axle Loading	Laden (Front / Rear)		kg	2980/655	3565/615	3855/595	4285/590	4935/745	5740/945	6160/990	6735/1035	2980/655	3545/615	3855/595	4285/590	4935/745	5740/945	
	28	Axle Loading	Unladen (Front / Rear)		kg	1265/1370	1250/1580	1280/1670	1260/1860	1605/2075	1560/2625	1555/2845	1935/2835	1265/1370	1250/1580	1280/1670	1260/1860	1605/2075	1560/2625	
CHASSIS	29	Tyres: Number	Front / Rear (X=Drive)			2X/2	2X/2	2X/2	2X/2	2X/2	2X/2	2X/2	2X/2	2X/2	2X/2	2X/2	2X/2	2X/2		
	30	Tyres	Front		mm	6.00-9-10PR	6.00-9-10PR	21x8-9-14PR	21x8-9-14PR	23x9-10-16PR	23x9-10-16PR	23x9-10-16PR	28x9-15-12PR	6.00-9-10PR	6.00-9-10PR	21x8-9-14PR	21x8-9-14PR	23x9-10-16PR	23x9-10-16PR	
	31	Tyres	Rear		mm	5.00-8-8PR	5.00-8-8PR	5.00-8-8PR	5.00-8-8PR	18x7-8-14PR	18x7-8-14PR	18x7-8-14PR	6.50-10-10PR	5.00-8-8PR	5.00-8-8PR	5.00-8-8PR	5.00-8-8PR	18x7-8-14PR	18x7-8-14PR	
	32	Wheelbase		y	mm	1250	1250	1250	1250	1400	1400	1400	1600	1250	1250	1250	1250	1400	1400	
	33	Thread	Front		mm	890	890	900	900	955	955	955	955	890	890	900	900	955	955	
	34	Thread	Rear		mm	900	900	900	900	945	945	945	980	900	900	900	900	945	945	
	35	Ground clearance	Min.		mm	95	95	95	95	95	95	95	130	95	95	95	95	95	95	
	36	Ground clearance	Middle of wheelbase	F	mm	110	110	110	110	110	110	110	110	235	110	110	110	110	110	
	37	Service brake					Hydr.	Hydr.	Hydr.	Hydr.	Hydr.	Hydr.	Hydr.	Hydr.	Hydr.	Hydr.	Hydr.	Hydr.	Hydr.	
MOTORS	38	Parking brake	Foot / Hand / Deadman			Hand	Hand	Hand	Hand	Hand	Hand	Hand	Hand	Hand	Hand	Hand	Hand	Hand		
	39	Type				BS/JIS	BS/JIS	BS/JIS	BS/JIS	BS/JIS	BS/JIS	BS/JIS	BS/JIS	BS/JIS	BS/JIS	BS/JIS	BS/JIS	BS/JIS		
	40	Battery	Voltage / Ampere hrs (5HR)	V/Ah		48/330	48/330	48/400	48/400	48/450	48/565	48/565	72/450	48/330	48/330	48/400	48/400	48/450	48/565	
	41	Weight (with case)		kg		630	630	740	740	820	880	880	1240	630	630	740	740	820	880	
	42	Drive Motor	60min. rating		kw	9.0	9.0	9.0	9.0	10.0	10.0	10.0	10.0	10.0	9.0	9.0	9.0	10.0	10.0	
	43	control				FET	FET	FET	FET	FET	FET	FET	FET	FET	FET	FET	FET	FET	FET	
	44	Hydraulic motor	5min. rating		kw	9.5	9.5	9.5	9.5	9.5	12.0	12.0	15.0	12.0	12.0	12.0	12.0	13.5	14.0	
	45	control				FET	FET	FET	FET	FET	FET	FET	FET	FET	FET	FET	FET	FET	FET	
	46	Power Steering Motor	60min. rating		kw	0.4	0.4	0.4	0.4	0.5	0.5	0.5	0.5	0.4	0.4	0.4	0.4	0.5	0.5	
	47	control				FET	FET	FET	FET	FET	FET	FET	FET	FET	FET	FET	FET	FET	FET	
	48	Type (Built-in / Stationary)				Stationary	Stationary	Stationary	Stationary	Stationary	Stationary	Stationary	Stationary	Stationary	Stationary	Stationary	Stationary	Stationary	Stationary	
	49	Charger (option)	Input	φ/V		3/400	3/400	3/400	3/400	3/400	3/400	3/400	3/400	3/400	3/400	3/400	3/400	3/400	3/400	
	50	Capacity		kVA		4.7	4.7	6.5	6.5	6.5	8.1	8.1	12.0	4.7	4.7	6.5	6.5	6.5	8.1	
	51	Operating Pressure	for Attachments	MPa		13.7	13.7	13.7	15.7	15.7	17.2	15.7	17.2	13.7	13.7	13.7	13.7	15.7	17.2	