



ENGINE POWERED FORKLIFT TRUCKS
FG-F1 Series
1.75-3.0 ton

ENGINE POWERED FORKLIFT TRUCKS
FG-F1 Series
1.75-3.0 ton



Model Name	Capacity
FHGE18TF1	1,750 kg
FGE25TF1	2,500 kg
FGE25TF1S	2,500 kg
FHGE25TF1	2,500 kg
FHGE30TF1	3,000 kg



TCM Industrial Forklift Trucks – The Ultimate Industrial Forklift Trucks.

From UniCarriers comes a cutting edge series of industrial forklift trucks. Rugged and reliable, TCM forklifts offer superior controllability, excellent front and rear visibility, and high-speed operation to help increase productivity and profit. No detail has been overlooked in improving operator safety, and maintenance has been made easier than ever. For the ultimate in performance, count on UniCarriers.



Excellent Eco-Friendliness

Serious consideration is paid to the operator and to the environment

Selection of the eco-mode provides even lower fuel consumption and lower operating noise (gasoline and LPG trucks)

You can select the eco-mode using the mode switch provided on the right side of the operator's seat. The eco-mode reduces fuel consumption and operating noise while maintaining a reasonable level of driving power. With the eco-mode selected, fuel consumption and CO₂ emissions are reduced about 11% compared with the power mode.

Overheating prevention (gasoline and LPG trucks)

If the coolant temperature rises excessively, the engine output is reduced automatically, to keep the engine from being seriously damaged.



A top speed reduction switch is also included in this option.

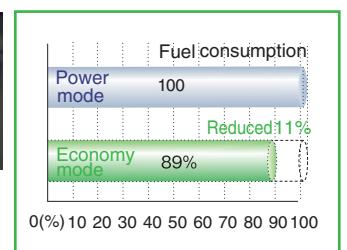

**Extra large floor space
designed into every capacity
TCM industrial forklift trucks!**



The wide-open floor space has been optimized for easier entry and exit, and more operator comfort. The uncluttered floor improves operator safety by eliminating tripping hazards and removing sharp edges with a minimal profile dashboard.

ENHANCED OPERATOR COMFORT AND SAFETY



1. New improved feature

Adjustable steering column with a special lever that allows automatic release and return to the users preferred position.

2. Standard full suspension seat

This comfortable seat features full suspension with adjustable weight compensation, seat belt and integrated operator presence system.

3. Ergonomically placed parking brake

The parking brake lever is located on the left side of the steering wheel in a location that does not interfere with operator entry or exit. The double action lever provides better control and reliability when setting the brake.

4. Operator presence interlock is standard on all models

The interlock system is a safety device that cuts off the power to the drive and load handling circuits if the operator leaves his seat during operation.

5. Easy-reach cup holder

A large cup holder is located within easy reach, and it can also be used to hold pens, small tools and other items during operation.

6. Operator comfort design

Comfortable pedal positions and a large floorboard area provide smooth and efficient operation with reduced operator fatigue.



**SUPERIOR
CONTROLABILITY,
SAFETY AND PRODUCTIVITY**

1. Better forward visibility

With low tilt cylinder mount position and a low profile dashboard, forward visibility is excellent. The steering wheel diameter has also been reduced to improve the visibility of the fork tips and load, helping enhance safety and reduce operator fatigue.

2. Automotive type directional and signal control

Easy to reach driving and signaling controls make for smooth operation. A neutral safety function prevents the engine from being started unless the directional control lever is in the neutral position.

3. Rear combination lamps

Turn signals, brake lights and back up lights and alarm are all standard features on TCM forklift trucks.

4. A small diameter steering wheel with a spinner knob is standard.

The diameter of the steering wheel is approximately 30cm, so the operator can control the steering wheel easily. This provides convenient entry and exit and improves forward visibility.

5. Special damper delivers stability and safety

A special damper cushions and stabilizes the axle for stable operation over uneven surfaces, giving outstanding reliability while traveling and in load handling operations.

6. Excellent operator control

The operating controls are located in an optimized configuration for improved functionality. The meter panel is conveniently placed so as not to obstruct operator view. The compact steering column is adjustable and features a memory lever to allow operators to quickly find their ideal driving position.

7. High visibility instrumentation

The instrument cluster monitors all the truck functions and incorporates LED technology that is easy to read, even in bright daylight.

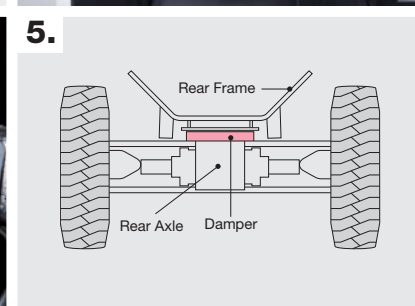

TCM TECHNOLOGY MEANS INCREASED DURABILITY



Swing down LPG bottle bracket (Option)

This feature allows for quick and easy change out of the LPG bottle, reducing operator down time and fatigue.



TCM

1.



1. Masts

With a low tilt cylinder position and heavy duty construction, masts provide optimal viewing and reliable load handling operation.

2. Steering axles

The solidly built steering axle delivers excellent performance and control in the harshest working environments.

3. Aluminum corrugated fin radiator

A standard feature on the F1 Series.

2.



EASY MAINTENANCE AND ENVIRONMENTAL FRIENDLINESS



Cleaner, more efficient engines

TCM F1 Series Forklift Trucks use Gasoline, LPG, and Dual fuel engines which meet the 2010 EPA and CARB emission control standards.

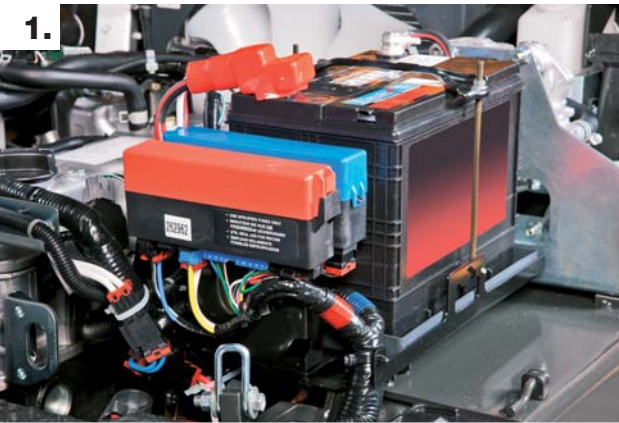

1. Easy access to major electrical components

The major electrical components are located together in the front of the engine compartment, for easy access.

2. Durable transmissions

TCM forklift trucks incorporate a simple and durable transmission that guarantees long life and quiet operation.

3. High-tech display

On Board Diagnostics interface located on the meter panel provides access to diagnostic trouble codes and data and also displays periodic maintenance reminders.

4. New feature

Easy access brake fluid reservoir makes checking and filling a simple, quick operation.

5. Easy-to-open floorboards

All components and assemblies are reliable and long lasting. However, if any of them should need replacement or repair, you can easily gain access to them by simply opening the floorboards.

Optional Equipment

Tilt leveling system



Smooth-run system



Side shifter



AirBoss® Tires



ENGINE POWERED FORKLIFT TRUCKS
FG-F1 Series
1.75-3.0 ton



ISO 9001 Certification
(Shiga Plant)



ISO 14001 Certification
(Shiga Plant)